

General technical features

PRINTING PERFORMANCE

- Max print area:
32 x 50 mm (SWING 1CE)
53 x 600 mm (SWING 2CE)
107 x 400 mm (SWING CL4)
128 x 400 mm (SWING CL5)
- High resolution: 12 dots/mm (300 dpi).
- Printing speed: from 10 to 750 mm/s in standard mode, extends to 1,000 mm/s in "GEAR MODE".
- Printing rate: with text 25 mm long max 300 prints/min (at a speed of 700 mm/s and max "ribbon saving")
- "Total Ribbon Saving" function. A further saving of 25% or 50% can be achieved in "GEAR-MODE".
- Longitudinal printing of expiry dates using the "TWILL" method, with total exploitation of the width of the thermal ribbon.
- Automatic re-processing of the date, hour and minutes without reducing the marking rate.

PRINTABLE TEXTS

- Texts with alphanumeric characters with a programmable height from 1 to 70 mm.
- Arial standard internal fonts; Windows TrueType fonts. Normal, bold, italic. Positive and negative printing.
- Symbols and characters UNICODE in the various languages (UTF-8 code).
- Text highlighting for allergens and ingredients to be printed. This function needs licensed EASYCODE® version.
- Bar-codes: EAN-13, EAN-8, EAN-128, UPCA, UPC-E, 2/5 Interleaved, Code 32, Code 39, Code 128 (A, C), ITF-14, Paraf, HIBC43, Binary.
- 2D codes: Datamatrix, PDF417, QR-Code, Databar.
- Graphics: Bit-image transmission type black/white with Eidos compression for the best use of the memory. BMP, PNG, TIF, JPG, PCX.
- Text orientation in the four quadrants.

SYSTEM CONFIGURATIONS

- **Stand-alone mode:** the printer can function also if not directly connected to a computer. The data is stored in non-volatile memories. New texts can be inserted in the printer by means of a USB Memory Card.
- **On-line mode:** the other way of working is a connection with an external processor. This can take place in three ways:
 - Serial connection type RS232 (to be programmed until 115.200 baud) or RS422 (optional).
 - Ethernet type connection by ETH-LAN integrated port.
 - Wireless connection type 802-11g via external adaptor.

ELECTRONIC UNIT

- 5.7" colour graphic display with touchscreen.
- "ARM" microprocessor. SMD technology with program and texts recorded in FLASH Memory.
- USB HOST port to manage a USB mobile memory and Flashreader devices.
- ETH-LAN port to connect Ethernet LAN 10/100.
- RS232 port.
- Possibility of connecting to Wi-Fi using an optional external adaptor.

LOGIC SIGNALS INTERFACE TO A PACKAGING MACHINE

- SYNC-24: synchronous signals.
- Fully opto-isolated logic signals (4 inputs and 4 outputs).

THERMAL RIBBON

Thermal ribbon autonomy: max 1,000 meters for versions "1ce" and "2ce"; max 500 meters for the "CL" version.

SOFTWARE TO MANAGE THE PRINTER

EASYCODE® is a powerful software designed by Eidos in a Windows environment to allow setting, memorisation, modification and printing of texts. The printer also interfaces with all the other leading label creating programs (CODESOFT®, LABELVIEW®, EASYLABEL®, NICELABEL®, BARTENDER®, BARONE®) by way of a SATO and ZEBRA ZPLII type emulator.

EXTERNAL POWER SUPPLY

- Electrical: 220 V a.c. 50 Hz. or 110 V a.c. 60 Hz.
- Power: 350 VA max.
- Compressed air: 6 Bar regulated, de-lubricated and filtered.
- Max consumption: 15 NI/min.

ENVIRONMENTAL CONDITIONS

- Operating temperature: from 0°C to 40°C. For operation at T≤10°C, it is necessary to use the inox heated protection box.
- Relative humidity: from 10% to 70% non condensing.
- Protection box available for wet or dusty environments.

SAFETY STANDARDS

The system complies with the provisions of current regulation regarding "Machine Safety" and CE marking.

MADE IN ITALY

The SWING MKII is designed and produced entirely in Italy by EIDOS.

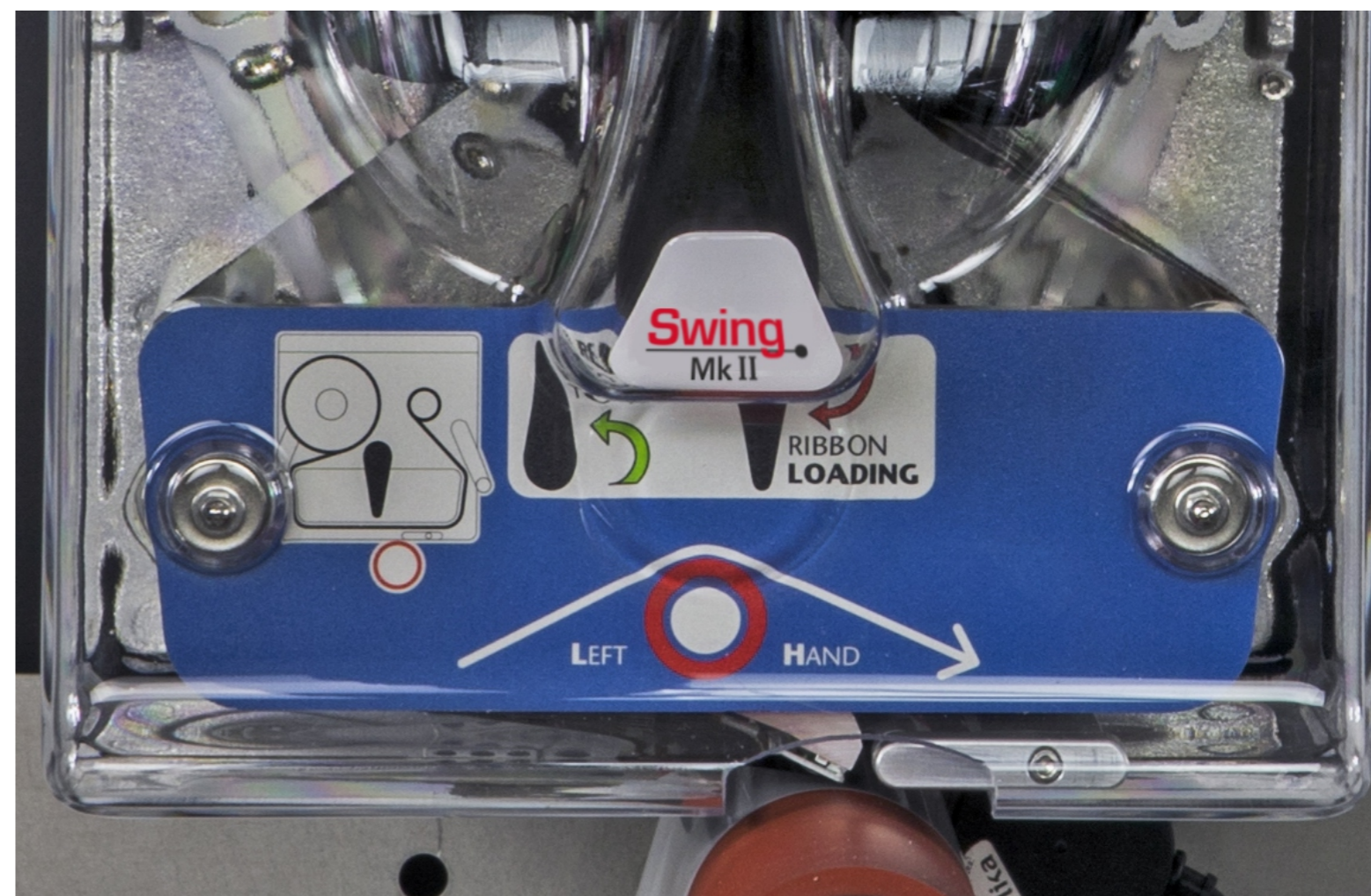

Marking technology engineering

Eidos S.r.l.
Via dell'Industria 11, Z.I. Fontaneto
10023 Chieri (TO), Italy
Tel. +39.011.947.781
Fax +39.011.947.7865
e-mail: info@eidos.eu - www.eidos.eu



For further information, view the Qr code with the mobile or please visit www.eidos.eu

The descriptions, information illustrations are not binding. EIDOS reserves the right to make changes or updates to the products described above without prior notice.
© EIDOS srl - All rights reserved. Partial or total reproduction is prohibited.

Swing MkII continuous

Thermal transfer printer to
directly print on plastic or paper
packaging film



Swing MkII

continuous

Printing in motion on continuous machines.

The continuous Swing MkII CE and CL Series devices are ideal heat transfer printers for overprinting variable data (forward or backward number sequences, text, ingredient lists, barcodes, two-dimensional codes, logos) on plastic or paper film on continuous packaging machines when the printing operation must be performed in motion.

The fixed head printer can be used to print directly on the production line when the product is packaged to the benefit of printing speed and quality.

The Swing prints in synch with the packaging machine speed. Since the movement speed of the film is not constant an encoder device must be fitted on the printing roller to ensure synchronism between the printing speed and the film speed.

Swing MkII: original, enveloping device.

The evolution of the EIDOS Swing series has smart new design. It is extremely compact, rugged and strong, simple to use. Maintenance is minimal.

Speed, flexibility and simplicity: these are the keywords of the Swing MkII.

- **Compact and light** printing unit for installation even in small spaces. Suitable for replacing obsolete mechanical markers. Thermal ribbons cost about half the foil used by hot markers.
- Changes or actions on printing parameters are viewed directly on the graphic display touchscreen, from computer or USB flash drive.
- **High-quality, high-definition prints.**
- **Direct marking** on the production line with product customisation during packaging to avoid the need for a large store of pre-printed rolls.
- Speed up to 1,000 mm/s or up to 350 prints/minute for high-definition applications (300 dpi).
- Possibility of automatic coding batches with variable data (date, forward or backward number sequences, text in various languages, ingredient lists, barcodes, two-dimensional codes, logos).



- Text can be retrieved from the large internal memory simply by pressing a button.
- Data exchange with USB memory or with connection to external PC for high reliability.
- Swing has a bracketing system ready for the most popular machines and comes in a variety of models.
- **Quick and easy ribbon replacement:** the new MkII version of the SWING printer offers design and ergonomic solutions which are expressly studied to facilitate routine maintenance operations and guarantee better protection of the moving parts of the printer.
- **Long autonomy** and fewer ribbon changes by using 1,000-metre-long thermal ribbons (500 metres for CL versions).



The ideal solution for overprinting variable data on plastic or paper film directly on the production line.

Compact and light printing unit.

The Swing MkII continuous printing unit is robust and reliable even at fast printing rates.

The facilitated ribbon threading systems makes maintenance quick and easy: open all crossing points by operating a lever, insert the new ribbon, unwind it with one hand following a linear path and finally fix it to the rewinding spool which is readily set up with an adhesive base. Then, close the lever and let the printer take the ribbon automatically to working position.

It all takes less than 30 seconds.

These printers can fit ribbon rolls up to 1,000 metres long, to the advantage of fewer ribbon changes and higher autonomy.

Two stepper motors move the ribbon during printing operations and retrieve it at the end.

All models may be provided with LEFT HAND or RIGHT HAND configuration. The configuration can be chosen according to the assembly position on the production line.

Supports for all films.

In order to facilitate assembly of the printing unit also in positions which are not easy to reach by the operator, EIDOS has designed a special support provided with bracket or sliding carriage to move the printer and place it in front of the operator.

Various models are available for film widths up to 600, 800 or 1,000 millimetres.

Stainless steel support

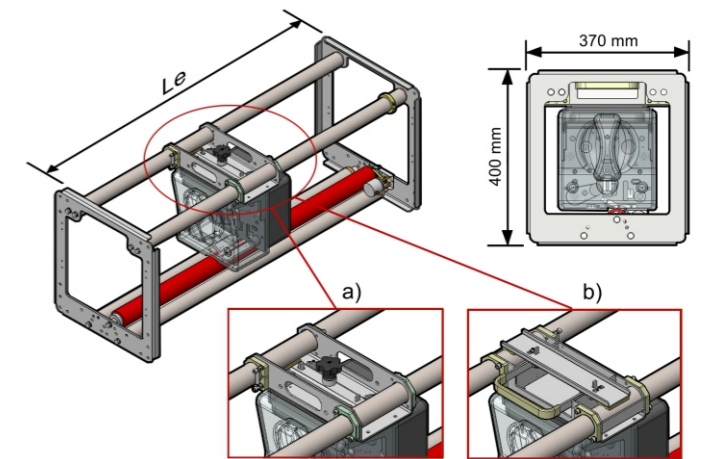

*Le = outer width of the support plates
Le min = 400 mm for SWING CL, 320 mm for SWING 2ce
Le max = 1500 mm
a) semi fixed bracket
b) sliding carriage*

Aluminium "L"-shaped support

The support with "L"-shaped side flanges and sliding carriage is available for the LEFT HAND (LH) and RIGHT HAND (RH) versions.

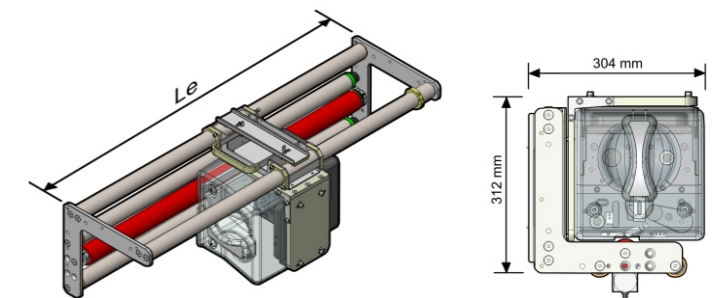

*Le = outer width of the support plates (including screws)
(Le min = 400 mm; Le max = 1500 mm)*

Models	LEFT HAND "LH"	RIGHT HAND "RH"
 SWING.CE MkII	SWING 1CE.LH	SWING 1CE.RH
	Electronic Unit: Low Power Print Area Max. 32 x 50 mm	
 SWING 2CE	SWING 2CE.LH	SWING 2CE.RH
	Electronic Unit: Low Power or High power Print Area Max. 53 x 600 mm	
 SWING.CL MkII	SWING CL4.LH	SWING CL4.RH
	Electronic Unit: High Power Print Area Max. 107 x 400 mm	
 SWING CL5	SWING CL5.LH	SWING CL5.RH
	Electronic Unit: High Power Print Area Max. 128 x 400 mm	